

BER Enhancement of CDMA system using Broadside Antenna array and SDMA in Rayleigh Fading Channel environment

Eng: Hassan Elesawy, Dr: Abdalmonem Fouda, Dr: W. Swelam, Prof. Dr. Ismail Mohamed Hafez

Abstract – Code Division Multiple Accesses (CDMA), one of the effective and efficient technologies, is used in 2nd generation (2G), 3rd generation (3G) wireless and becomes one of potential candidates for the physical layer of 4G mobile systems with the aim of improving cell capacity communication. The paper presents the CDMA system with Broadside antenna array is proposed for a multipath fading channel. The performance is evaluated in terms of bit error probability (BER) for the DS/CDMA system environment with QPSK modulation is use in the Rake Receiver with coding technique. The Standard Gaussian Approximation (SGA) is used to evaluate the performance of coding and Rake Receiver over a frequency selective Rayleigh fading channel with antenna array is estimated. From the analytic to Rayleigh fading results, the performance is evaluated for CDMA systems on additive white Gaussian noise (AWGN) and a multipath fading channel. Analytical expression of the BER is derived, including the effects of the spatial correlation between antenna elements and non-identical fading for different multipath. In the receiver, despreading and demodulated, coding, Rake Receiver, directive antenna (Broadside array antenna) are employed to improve the system performance. We examined the BER performance of Rake Receiver with, varying the number of users, spreading factor, Rake fingers, Interfering Cells, and the value of directivity of antenna at base Station (number of antenna). Antenna arrays are majorly used: Broadside array and End fire array. They are used to radiate their own beam patterns. The antenna arrays with different arrangements: The Spacing of the elements and the Number of elements may produce the diverse radiation properties. The overall radiation pattern results in certain directivity and different lobes with different number of elements and different spacing between them.

Index Terms - CDMA system, Broadside array and End fire array, Rake Receiver, Maximal Ratio Combining (MRC), Multipath channel, Directive antennas (Antennas array).

1 INTRODUCTION

CDMA system is one of the fastest growing market areas in both military and civilian wireless communications. However, multiple access interference (MAI) and multipath fading are the major limiting factors in the performance of CDMA mobile system. One approach to combat these problems is to use of antenna arrays at the base station. With optimum combining, antenna arrays can suppress MAI and mitigate multipath fading of the intended user, thereby improving the system performance considerably [1,2]. The goal for the third generation of mobile communications system is to integrate a wide Variety of communication services such as high speed data, video and multimedia traffic as well as voice signals. Under the CDMA System environment the Third Generation (3G) has many advantages such as highly efficient spectrum utilization and variable user data rates. MAI causes degradation in bit error rate (BER) and system performance which is reflected as a limitation in the system capacity. Therefore, any analysis of performance of a CDMA system has to take into account the amount of MAI and its effects on the parameters that measure the performance (most notably the signal-to-interference-and-noise ratio (SINR) at the receiver and the related bit error probability on the information bit stream). Much work has been reported on the calculation of the user average bit error rate for DS-CDMA systems.

The most widely used and popular approach is the Gaussian Approximation (GA) [1] and its variants. Hence, the present research activities are focused on reducing this interference. One approach that has shown real promise for substantial performance enhancement is the use of spatial processing by adopting adaptive antenna arrays at the mobile base station.

In this paper, we are interested in antenna arrays for CDMA systems under correlated multipath fading channels. An antenna array with N elements has $N-1$ degrees of freedom. When the number of interferers is larger than the number of antennas, the array cannot suppress all interfering signals, and this case is of our main concern. Usually the radiation pattern of a single element is relatively wide, and each element provides low values of directivity (Gain). In many applications, it is necessary to design antennas with very high directive characteristics (very high gain) to meet the demands of long distance communication. This can only be accomplished by increasing the electrical size of the antenna [3]. Enlarging the dimensions of single elements often leads to more directive characteristics. Another way to enlarge the dimensions of the antenna, without increasing the size of individual element, is to form an assembly of radiating elements in an electrical and geometrical configuration. This new antenna formed is referred to as an array [1].

These improvements in system performance CDMA mainly depend on the antenna beam pattern and antenna directivity (Broadside array) [4]. To illustrate how directive antennas can improve the reverse link in a single-cell CDMA system. The omnidirectional receiver antennas will detect signals from all users in the system, and thus will receive the greatest amount of noise. The sectored antenna will divide the received noise

1-Eng.: Hassan Elesawy, Faculty of Engineering, Ain Shams University, Cairo-Egypt, hassanelesawy@yahoo.com.

2-Dr:AbdalmonemFouda - Modern Academy; (fouda1964@yahoo.com).

3- Dr: W. Swelam, Ain Shams University, Cairo-Egypt,

4 -Prof. Dr. Ismail Mohammed Hafez, Chairman of Electronics and Communication Eng. Dept., Faculty of Engineering, Ain Shams University, Cairo-Egypt., imhafez@yahoo.com,

into a smaller value and will increase the number of user (capacity) in the CDMA system. The adaptive antenna will be used to simultaneously steer energy in the direction of many users at once, so it provides a spot beam for each user, and it is this implementation which is the most powerful form of SDMA [5, 6]. The CDMA mobile communication system employs at the transmitter a convolution channel coding, a considerable enhancement was obtained on the system performance. CDMA as a digital communication over mobile channels, often suffer from performance degradations due to multipath fading effects. RAKE receiver, used specially in CDMA systems to reduce fading effect, can combine multipath components, which are time-delayed versions of the original signal transmission. This combination is done in order to improve the signal to noise ratio (SNR) at the receiver. RAKE receiver attempts to collect the time shifted versions of the original signal by providing a separate correlation receiver for each of the multipath signals. This can be done due to multipath components are practically uncorrelated from another when their relative propagation delay exceeds a chip period [4]. We assume that each channel consists of multipath that are resolved in space but not in time [2,5]. Spatial processing is a kind of spatial separation between users using Space Division Multiple Access (SDMA) technique. In an SDMA system, the base station does not transmit the signal throughout the area of the cell, as in the case of conventional access techniques, but rather concentrates power in the direction of the mobile unit the signal is meant to reach, and reduces power in the directions where other units are present by using Broadside array antenna at the mobile base station.

The paper is divided into different sections. In section 2, a system model for CDMA system is presented which gives the basic equation in terms of number of users. In section 3, BER Performance Analysis' in channel used AWGN, Rayleigh fading, coding, Rack receiver and Broadside Antenna array will be investigated; accordingly the modification of the basic BER equation is presented; as well as the BER calculations for single antenna element and multiple antenna element. In section 4, Numerical Results, analytically determine the performance of the CDMA system using single and antenna array over Rayleigh fading channel using coding, Rack Rx and Broadside AA. Finally, the conclusion is presented in section 5.

2- SYSTEM AND CHANNEL MODEL:

2.1. Reverse Link System Model:

In this section we offer mathematical description of an asynchronous DS-CDMA system for reverse link (mobile to base station) with M_c interfering cells that supports K active users. This System is shown in Fig.1 the Reverse-link System. Let there are K active users transmitting signals in DS-CDMA system [1]. Each of them transmitting a signal which is described as

$$S_k(t - \tau_k) = \sqrt{2P_k} b_k(t - \tau_k) a_k(t - \tau_k) \cos(w_c t - \theta_k) \quad (1)$$

Where $b_k(t)$ is binary data sequence, $a_k(t)$ is a pseudorandom sequence, P_k is the power of the transmitted signal, w_c is the carrier angular frequency, τ_k is the time delay that accounts

for the lack of synchronism between the transmitters, and θ_k is the phase angle of the k^{th} carrier.

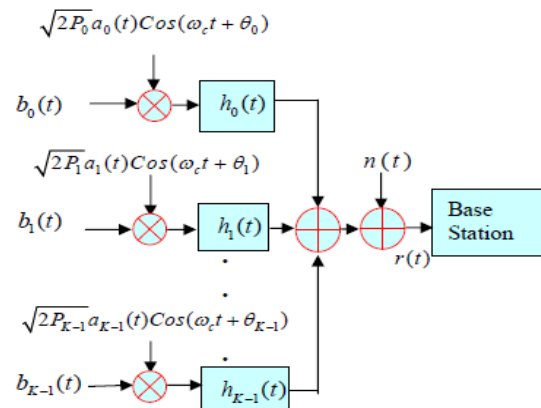

Fig.1. Reverse link system model

The k^{th} user's data signal is a sequence of unit amplitude rectangular pulse of duration T_b , taking values $\{-1,+1\}$. If T_c is the chip period and there are N_c chips per bit thus $N_c = T_b/T_c (= r_c/r_b)$ is the spreading factor for user k . Let the desired user is $k = 0$ and all other users contribute to MAI.

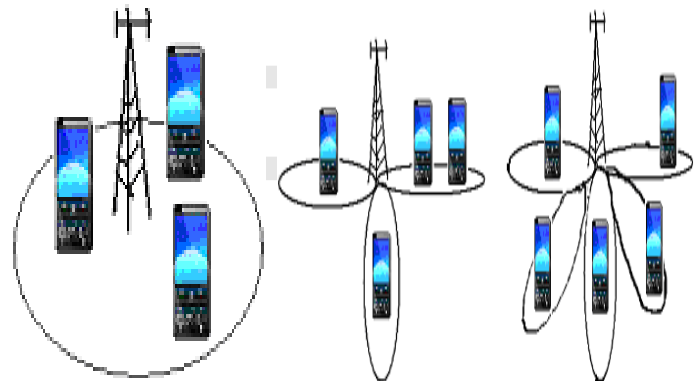

Fig.2. Omnidirectional antenna - sectored antenna - Adaptive antenna

2. 2. MULTIPATH CHANNEL MODEL

Multipath can occur in radio channel in various ways such as, reflection and diffraction from buildings, and scattering from trees presented in Figure 3. An M-ray multipath model is shown in Figure 4, which is an extension to the multipath channel model presented in [7]. Each of the M paths has an independent delay, τ , and an independent complex time-variant gain, G .

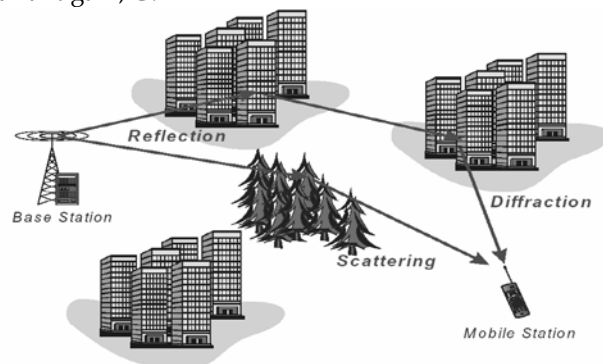

Fig.3. Propagation mechanisms

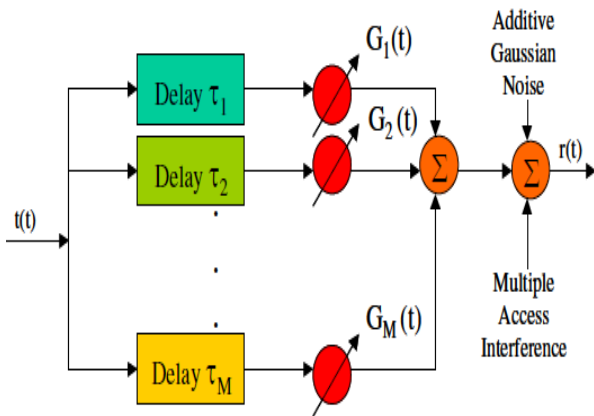

Figure.4. Multipath channel model

If the channel has a constant gain and linear phase response over a bandwidth that is smaller than the bandwidth of transmitted signal, then the channel creates a frequency selective fading on the received signal [7]. In this channel, the gain is different for different frequency components. Frequency selective fading is caused by multipath delays which approach or exceed the symbol period of the transmitted symbol. We assume that channel $h_k(t)$ is multipath Rayleigh frequency selective fading channel. The delay difference between any two different paths is larger than the chip duration T_c . The complex low pass equivalent impulse response of the channel is given by:

$$h_k(t) = \sum_{l_k}^{L_k} \alpha_{k,l_k} e^{j\phi_{k,l_k}} \delta(t - \tau_{k,l_k}) \quad (2)$$

Where ϕ_{k,l_k} the phase of the multipath component, τ_{k,l_k} is the path delay, and L_k is the number of multipath components. α_{k,l_k} is the magnitude of the l_k th multipath with Rayleigh distribution [8,9]. The received signal at the input of the receiver is given by:

$$r(t) = \sum_{k=0}^{K-1} \sum_{l_k}^{L_k} \sqrt{2P_k} \alpha_{k,l_k} b_k(t - \tau_{k,l_k}) a_k(t) \cos(t - \tau_{k,l_k}) \cos(\omega_c t - \phi_{k,l_k}) + n(t) \quad (3)$$

Where $n(t)$ is Additive White Gaussian Noise (AWGN) with a two sided power spectral density of $N_0/2$. Where N_0 is the noise power spectral density measured in watts/hertz (joules).

2.3. UNIFORM ARRAY ANTENNA:

The performance of single antenna elements is poor compared to that of antenna arrays. In an antenna array, the number of elements, the spacing between them, their excitation coefficients, and their relative phases are parameters that can be adjusted not only to increase the antenna gain but also to narrow the beam (i.e. decrease the beamwidth), steer the beam in a given direction, and/or control the side lobes level (by adjusting the excitation coefficients of the antenna array, e.g. using the Dolph-Chebyshev method [10]). These factors determine the array factor which is used in the calculation of the array directivity and consequently the array gain. The to-

tal field of an array can be calculated by multiplying the field of a single element at a selected reference point (usually the origin) and the array factor. The general formula for the calculation of directivity in a direction (θ_0, ϕ_0) is given by:

$$D(\theta_0, \phi_0) = 4\pi / \{ \int_0^{2\pi} \int_0^\pi |F(\theta, \phi)|^2 \sin\theta d\theta d\phi \} \quad (4)$$

Where $F(\theta, \phi)$ is the power factor in the case of isotropic elements, the power factor is given by:

$$F(\theta, \phi) = AF(\theta, \phi)AF^*(\theta, \phi) \quad (5)$$

Where AF is the array factor and $*$ denotes the complex conjugate operation. The array gain is equal to the directivity multiplied by the loss coefficient which in turn depends on the antenna type. When the losses are negligible, the gain is approximately equal to the directivity [10]. Widely used antenna arrays are the uniform linear arrays where the radiating elements are placed on a line with equal spacing and excitation in addition to uniform circular arrays where the radiating elements are uniformly distributed on a circle with equal excitations.

The normalized array factor of an N element uniform linear array (ULA) with equal amplitude excitation and inter element spacing d is given by [11]:

$$AF_{ULA}(\theta) = (1/N) [\sin(0.5N\Psi) / \sin(0.5\Psi)] \quad (6)$$

It should be noted that if the array is aligned along the z -axis show Fig.5. Then

$$\Psi = kd \cos(\theta) - kd \cos(\theta_0) \quad (7)$$

Since each isotropic element has unity amplitude, the entire behavior of this array is dictated by the phase relationship between the elements. The phase is directly proportional to the element spacing in wavelengths. Where $\theta_0 =$ electrical Phase difference between the adjacent elements, (steering angle) direction of maximum radiation, $d =$ distance between the elements; $k = 2\pi/\lambda$ constant phase shift (wave number); $\theta =$ angle as measured from the z axis in spherical coordinates, and k is the wave number. To steer the beam in the direction θ_0 , the progressive phase between the elements should be $-kd \cos(\theta_0)$. Equation (6) is independent of Ψ since it expresses the array factor of a linear array in the vertical direction. Hence, the pattern will be omnidirectional in the azimuth plane. To use the array in adaptive antenna techniques, it should be placed in the azimuth plane. Its pattern will still exhibit the same form but its mathematical expression will become more complex.

The normalized array factor of an N element uniform circular array (UCA) of radius r is given by [10]:

$$AF_{UCA}(\theta, \phi) = \sum_{n=1}^N I_n e^{jkr[\sin\theta \cos(\theta - \phi_n)]} \quad (8)$$

Where $\phi_n = 2\pi(n - 1)/N$. To steer the beam in the direction (θ_0, ϕ_0) , the phase of the excitation coefficients I_n should be set to $-\sin\theta_0 \cos(\phi_0 - \phi_n)$ (their magnitude is I since the array is uniform).

Antennas are often referred to by the type of pattern they produce. Two terms that usually characterize array antennas, are broadside and end fire. The phasing of the uniform linear array elements may be chosen such that the main lobe of the array pattern lies along the array axis (end-fire array) or nor-

mal to the array axis (broadside array). Thus for a uniform array with $\theta_0 = 0$ and $d = n\lambda$, in addition to having the maxima of the array factor directed broadside ($\theta = 90^\circ$) to the axis of the array, there are additional maxima directed along the axis ($\theta = 0^\circ; 180^\circ$) of the array (end fire radiation).

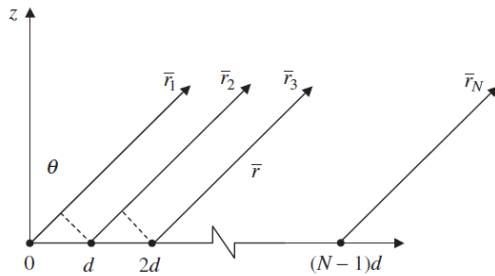

Fig.5. An N-element linear array along z axis

$$r_1 = r_2 = r_3 = r_N = r;$$

$$r_N = r + (N - 1)d \cos r_N = r + (N - 1)d \cos$$

2.3.1 Broad side array: Broad side array is the arrangement of identical antennas, which are placed along the axis perpendicular to the direction of maximum radiation. The identical antennas are equally spaced along the line of axis and all the elements are fed with equal magnitude of current with the same phase. This results in array pattern known as broad side array. It is evident that broad side array is bidirectional where maximum radiation is obtained in the direction of axis perpendicular to the array axis. By placing an identical array at a distance of $\lambda/4$ behind the array, bidirectional array can be converted to unidirectional array and by lead current in phase by $\lambda/2$.

-Directional antennas whose mechanical features are orthogonal to the main radiation beam are called "Broadside Arrays" (BSA). The directivity of the array factor can be evaluated using:

$$D_{BSA} = 4\pi u_{max}/P_{rad} = u_{max}/u_0; \quad (9) \text{ Where } u_0 \cong \pi/Nkd$$

$$D_{BSA} = 2/\int_0^\pi \sin(\theta) [\sin(0.5Nkd\cos(\theta))/\sin(0.5Nkd\cos(\theta))]^2 d\theta \quad (10)$$

$$x = 0.5Nkd \cos(\theta); \quad \beta = 0; \quad dx = -0.5Nkd \sin(\theta)d\theta$$

$$D_{BSA} = Nkd/\int_{-0.5Nkd}^{0.5Nkd} (\sin(x)/x)^2 dx; \quad \text{At } 0.5Nkd \gg \pi;$$

$$D_{BSA} \approx 2Nd/\lambda; \quad d = \lambda/2;$$

$$D_{BSA} = N(\text{number of antenna}) \quad (11)$$

The overall array field pattern is

$$F(\theta, \phi) = (1/N) [\sin(0.5N\pi\cos\theta)/\sin(0.5\pi\cos\theta)] * \sin\theta \quad (12)$$

2.3.2 END FIRE ARRAY: An End fire array looks similar to broad side array except that the individual elements are fed with the current that is equal in magnitude but opposite in phase. In other words, the individual elements are excited in such a way that a progressive phase difference between adjacent elements becomes equal to the spacing between the antennas (elements). "The arranging of identical antennas along a line drawn perpendicular to their respective axis so that the principle direction of radiation coincides with the direction of the axis of array" is known as End fire array. The radiation is maximum in the direction along the axis of the array i.e., 0 degree (or) 180 degree. If two equal radiators are operated in

phase quadrature at a distance of $\lambda/4$ apart, an end fire couple is said to be formed. The directivity of the array factor can be evaluated at $\beta = -kd, 0.5Nkd \gg \pi; D_0 \approx 4Nd/\lambda$, The end-fire array has twice the directivity of the broadside array.

Directional antennas whose mechanical features are parallel to the main radiation beam are called "End-fire Arrays".

The overall array field pattern is

$$F(\theta, \phi) = (1/N) [\sin(0.25N\pi(\cos\theta - 1))/\sin(0.25\pi(\cos\theta - 1))] * \sin\theta \quad (13)$$

2.3.3. PARAMETERS AFFECTING ARRAY ANTENNA

For the design of Lanier array, one has to adequately choose the number of antennas in the array (N), their position on the Lanier (inter element spacing (d) and the length (k). Also, the control function of the complex weighting coefficients (beam forming factor W) should be specified in order to obtain the desired radiation pattern with a suitable resolution. These parameters were reflected directly on the antenna directivity (D) and on the communication system performance (BER). The Beam width is inversely related to spacing between the antenna elements. We obtain a narrow beam width when the antenna spacing is large, however it is required that the spacing will be less than $\lambda/2$, where λ is the wavelength of the radiated frequency, else we get spurious beams apart from the required ones. Number of antennas elements also affect the beam width inversely, more the elements, less the beam width. Additionally we have a reduction inside lobes amplitudes, with more antenna elements [14].

3.BER PERFORMANCE ANALYSIS :

For interference limited asynchronous reverse channel CDMA over non faded additive white Gaussian channel (AWGN) channel, operating with perfect power control with no interference from adjacent cells and with omnidirectional antennas used at the base stations, the average bit error rate (BER) P_b , for a user can be found from the Gaussian Approximation(GA) [15].

$$P_b = Q(\sqrt{3N/(K-1)}) \quad (14)$$

Where $Q(x)$ is the standard Q-function. Assume that a beam pattern $F(\beta = (\theta, \phi))$ in equation (12), is formed such that the pattern has maximum gain in the direction of the desired user. Such a directive pattern can be formed at the base station using an N-element linear array antenna. The pattern, $F(\beta)$ can be steered through 180° in the horizontal (β) plane such that the desired user is always in the main beam of the pattern. It is assumed that K users in the single-cell CDMA system are uniformly distributed throughout a two-dimensional cell (in the horizontal plane, $\theta = \pi/2$), and the base station antenna is capable of simultaneously providing such a pattern for all users in the cell. On the reverse link, the power received from the desired mobile signals is $P_{r,i}$. The powers of the signal incident at the base station antenna from K-1 interfering users are given by for $i = 1, \dots, k-1$. The average total interference power, I, seen by a single desired user, (measured in the received signal at the array port of the base station antenna ar-

ray, which is steered to the user 0), is given by:

$$I = E \left\{ \sum_{i=1}^{K-1} F(\beta_i) P_{r,i} \right\} \quad (15)$$

Where β_i is the direction of the k^{th} user in the horizontal plane, measured in the x-axis, and E is the expectation operator. No interference from adjacent cells contributes to total received interference in equation (6) [15]. Assuming perfect power control is applied such that the power incident at the base station antenna from each user is the same, then P_c for each of the K users, base station antenna pattern has no variation in the θ direction and the users are independently and identically distributed throughout the cell. The average bit error rate for user 0 can thus be given by [1]:

$$P_1 = Q(\sqrt{3DN/(K-1)}) \quad (16)$$

Where D is the directivity of the antenna, given by $\text{Max}(F(\beta_i))$. In typical cellular installations, D ranges between 3 dB to 10 dB [1]. Equation (16) is useful in showing that the probability of error for a SDM-CDMA system is related to the beam pattern of a receiver, and there it is immediately apparent that the gain of the antenna directly contribute to the performance of a CDMA system. A considerable improvement that is achieved by using a high directivity adaptive linear array antenna at the base station.

3-1- BER FOR A MULTI-CELL SDMA-CDMA SYSTEM IN RAYLEIGH FADING CHANNEL:

In real case we should consider the interference signals from mobiles within cells and outer cells (adjacent cells) as shown in Fig.6. Clearly

For CDMA operating in a Frequency selective Rayleigh Fading and Additive White Gaussian Noise (AWGN) channel, with perfect power control with interference from adjacent cells equipped by a conventional correlated- type receiver at the base station and with no channel coding at the transmitter and with using SDMA-CDMA technique by using adaptive array antennas at the base station, the average Bit Error Rate (P1), be found from the Standard Gaussian Approximation (SGA) as [4] [15] (without coding).

The BER for user 0 can thus now be given (14).

$$P_0 = 0.5 - \left[\frac{1}{\sqrt{1 + (N_0/2E_b) + (2/3DN_c) [(1 + 0.2M_c)LK - 1]}} \right] \quad (17)$$

Where E_b/N_0 = Signal to Noise (AWGN) ratio. N_c = Processing gain of the CDMA system (spreading factor). M_c = Number of interfering cells; L = Number of channel multi paths; each of them independently faded with Rayleigh statistics. K = Number of user.

From the equation (11) into the equation (16)

$$P_1 = 0.5 - \left[\frac{1}{\sqrt{1 + (N_0/2E_b) + (2/3DN_c) [(1 + 0.2M_c)LK - 1]}} \right]$$

At $D_{BSA} = N = N_a$ from equation (11)

$$P_1 = 0.5 - \left[\frac{1}{\sqrt{1 + (N_0/2E_b) + (2/3N_a N_c) [(1 + 0.2M_c)LK - 1]}} \right] \quad (18)$$

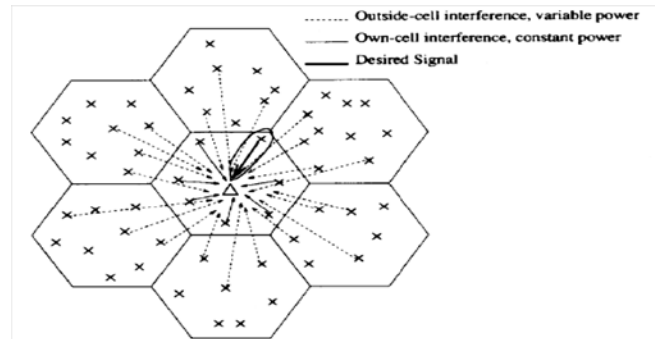

Fig.6-a: Multi Cell Interference with a Directive Antenna at the Base Station;

3-2- BER FOR SDMA-CDMA SYSTEM USING CONVOLUTION ENCODING(ERROR CONTROL CODING):

The general block diagram of the communication system for the reverse link CDMA Coded Transmission is shown in Fig.7. In this new bit rate denoted by, is generated by the Convolution encoder which is transmitted along a noisy and faded channel. At the receiver, the Bit Error Rate following conventional correlated detection is denoted by, the Bit Error Rate at the output of the Rake Receiver is given by, and the Bit Error Rate at the output of the Viterbi Decoder is given by. Coding techniques can be used in channels with a lot of noise (high probability of error) to enhance the CDMA system performance. One of the appropriate coding used for this purpose is the convolution code. The convolutional code is generated by passing the information sequence to be transmitted through a linear finite state shift register. In general, the shift register consists of (k- bit) stages and n linear algebraic function as shown in Fig.7. The input data to the encoder, which is assumed to be binary, is shifted into and along the shift register k bits at a time. The number of output bits for each k-bit input sequence is n bits. Consequently, the code rate is defined as $R=k/n$. The parameter is called the constraint length of the convolution code C_L [16].

In this paper we use convolution coding scheme at the transmitter and associated viterbi decoding scheme at the receiver. The state diagram of the encoder is simply a graph of the possible state of the encoder and the possible transitions from one state to another. Since the output of the encoder is determined by the input and the current state of the encoder, a state diagram can be used to represent the encoding process. Fig.8 shows the state diagram of 1/3 rate convolutional encoder. A dotted line in the graph indicate that the input is a 1, while the solid line indicates that the input bit is a 0. The distance properties and the error rate performance of a convolutional code can be obtained from its state diagram. The state diagram in Fig.10 will be used to obtain the distance properties of the convolutional code. We label the branches of the state diagram as either $D^0 = 1, D, D^2, \text{ or } D^3$, where the exponent of D denotes the Hamming distance of the sequence of output bits corresponding to each branch from the sequence of output bits corresponding to the all zero branch [9].

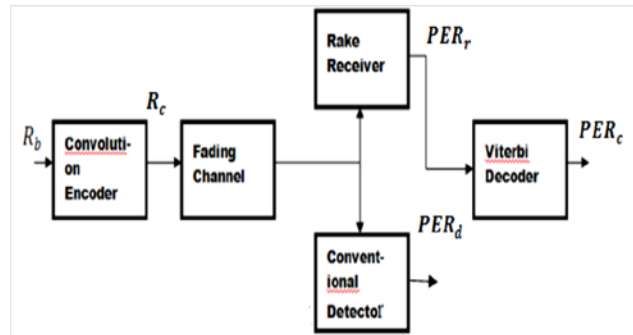

Fig.7. Coded Transmission System.

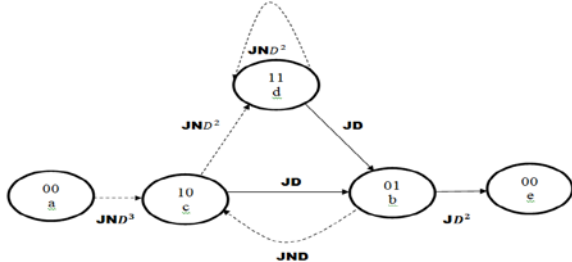

Fig.8. State diagram of 1/3 rate Convolution encoder.

The state equations of the convolution encoder can be deduced from Fig.10 and is given by equation (15) as:

$$\begin{aligned} X_c &= JND^3X_a + JNDX_b; & X_b &= JDX_c + JDX_d; \\ X_d &= JND^2X_c + JND^2X_d; & X_e &= JD^2X_b \end{aligned} \quad (19)$$

Where, the factor J was introduced into each branch of the state diagram so that the exponent of J will serve as a counting variable to indicate the number of branches in any given path from node a to node e. The exponent of the factor N indicates the number of 1s in the information sequence for that path and the exponent of D indicates the distance of the sequence of encoded bits for that path from all the zero sequence [7]. Upon solving the equations in (19) for the ratio X_c/X_e , we obtain the coder transfer function as:

$$T(D, N, J) = J^3ND^6 / [1 - JND^2(1 + J)] \quad (20)$$

The transfer function can be represented by the following power series:

$$\begin{aligned} T(D, N, J) &= J^3ND^6 + J^4N^2D^8 + J^5N^3D^{10} \\ &\quad + 2J^6N^3D^{10} + J^7N^3D^{10} + \dots \\ T(D, N, J)|_{J=1} &= ND^6 + 2N^2D^8 + 4N^3D^{10} + \dots \end{aligned} \quad (21)$$

Thus the transfer function gives us the distance properties of the convolution code. The minimum distance of the code is called the minimum free distance and is denoted by d_{free} . In our case, $d_{free}=7$. This form of transfer function gives the properties of all the paths in the convolutional code.

Coding is a technique where redundancy is added to original bit sequence to increase the reliability of the communication. In case of uncoded transmission, the output from the binary source could be applied directly to the modulator, spreader and transmitted as a channel waveform. At the receiver side we detect the signal and find the Bit Error Probability (BEP_u). In the case of uncoded transmission, the output (BER_u) is equal to the (BEP_u). The subscript 'u' is used for the uncoded quantities. Fig.9.a. shows the uncoded Transmission System. Where R_u is the uncoded input bit rate to the channel.

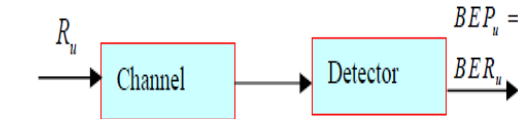

Fig.9.a. Uncoded Transmission System

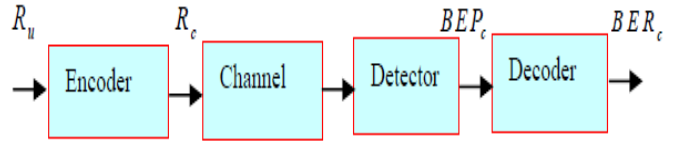

Fig.9.b. Coded Transmission System

The Bit Error Probability (BEP_u) for this system using SGA is given as equation (17) for [12]. In the case of uncoded transmission, the output Bit Error Rate (BER_u) is equal to the (BEP_u). Thus (13) gives the Bit Error Rate (BER_u) under perfect power control. Fig 9.b. shows the Coded Transmission System. In this new bit rate denoted by R_c , is generated by encoder which is transmitted along the channel. At the receiver the bit error probability following detection is denoted by BEP_c and the Bit Error Rate at the output of decoder is given by BER_c . The coded BEP_c is given by equation (17), [10].

$$P2 = 0.5 - \left[\frac{1}{\sqrt{1 + (N_o/2rE_b) + (2/3N_c) [(1 + 0.2M_c)LK - 1]}} \right] \quad (22)$$

Now the Coded BER_c is given as

$$BER_c \leq \frac{d}{dN} T(D; j; N)|_{j=1, N=1, D=2\sqrt{BEP_c(1-BEP_c)}}$$

3-3- BER FOR SDMA-CDMA SYSTEM USING RAKE RECEIVER

A RAKE receiver, shown in Fig.6.b, utilizes multiple correlators to separately detect M strongest multipath components. The outputs of each correlator are weighted to provide better estimate of the transmitted signal than is provided by a single component. Demodulation and bit decisions are then based on the weighted outputs of the M correlators. Each correlator detects a time-shifted version of the original CDMA transmission, and each finger of the RAKE correlates to a portion of the signal, which is delayed by at least one chip in time from the other fingers. Using Rake receiver with Maximal Ratio Combiner (MRC), considering perfect channel estimation, in the system having M number of fingers, the Bit error rate (BER) is given by [17]

$$BER = [0.5(1 - \mu)]^M \sum_{j=0}^{M-1} \binom{M-1+j}{j} \left[\frac{1}{2}(1 + \mu) \right]^j \quad (23)$$

Where the Broadside array antenna array antenna (BER_1) from equation (18) with the Rake receiver is given by:

$$\mu_1 = \sqrt{1 / \{1 + (N_o/2E_b) + (2/3N_a N_c) [(1 + 0.2M_c)LK - 1]\}} \quad (24)$$

The BER_1 system using Broadside array antenna and Rake receiver with MRC from (24) into (23) is $\mu = \mu_1$.

The coded (BER_2) from equation (22) with the Rake receiver is given by:

$$\mu_2 = \sqrt{1 / \{1 + (N_o/2rE_b) + (2/3 N_a N_c) [(1 + 0.2M_c)LK - 1]\}} \quad (25)$$

The BER2 system using coding and Rake receiver with MRC from (25) into (23) is $\mu = \mu_2$.

Let the modified We know that the noise at the output of the antenna array is reduced by N times. Hence,

$\sigma_N^2 = (N_0/2)/N_a$; Let H denote the number of in-beam interferers. The number of out-of-beam interferers = K - H - 1.

-we can obtain the average bit error probability of 2D-RAKE receiver as the probability of error of the CDMA system for Rayleigh fading channel and (N_a) antennas become:

$$P_b^{2D}(e) = \sum_{H=0}^{K-1} \chi \eta^H \binom{K-1}{H} \text{BER} \quad (26)$$

Where the probability of an in-beam interferer η , are defined as [18]: $\eta = \frac{2\theta_{BW}}{\Delta\theta}$, and χ depend on the beam stretching of antenna array ($1/\cos\theta$; in $\lambda(\theta)$) in practical in practical (when $\Delta\theta < 60^\circ - 120^\circ$) it can approximated as:

$$\chi = (1 - \eta)^{(K-H-1)} \quad [19],$$

4- NUMERICAL RESULTS:

In this section the BER performance of the DS-CDMA system using multiple BS transmit antenna arrays is investigated, when assuming that each subcarrier signal experiences flat Rayleigh fading channels and AWGN channel. The summary of the used numerical values will be listed in the following table 1: *Table1 Equivalent antenna array Parameters*

TABLE1
Equivalent Antenna Array Parameters

Number of antenna elements N_a	2	4	8	12	16
Attenuation α_0 dB	-10	-12	-16	-17	-18.25
total beam width $2\theta_{BW}$ (deg)	40	30	15	5	4

-This paper worked out a MathCAD simulating program for the CDMA system using QPSK -modulating and a rate 1/3, constraint length 6 ,maximum free distance convolutional code for spreading [16].

In this section, we present several numerical examples to illustrate the impacts of the operating environment (i.e. the Rice factor, the delay spread and angular spread) on the BER performance improvement with 2D-RAKE receiver in Recian fading channels. Without loss of generality, the Base Station antenna array is assumed to be a Uniform linear array with identical spacing $d = \lambda/2$ between elements, broadside receiving ($\theta = 0 \sim 2\pi$), and each path arriving at antenna array with the same angular spread. For the system asynchronous CDMA 2000 with antenna array in Rayleigh fading channels and AWGN channel.

Figure 10 shows the Simulation of A MATLAB program was used to plot the radiation patterns of a ULA antenna(broadside and end fire) depending on equation (12,13) in the polar plan and as 3-D plot as shown in figure 10, considering as an application a reverse link SDMA-CDMA mobile system with transmitted frequency of 1.9 GHz [16]. For this application the simulation results show that the antenna two element distance ($d=(0.25, 0.5, 1) \lambda$) is suitable as a mechanical dimension

to be mounted on the mobile base station . The type of radiation pattern is controlled by the choice of phase shift angle between the elements. Zero phase shift produces a broadside pattern and 180° phase shift leads to an endfire pattern, while intermediate values produce radiation patterns with the mainlobes between these two cases.

In Fig.11: shows the BER vs SNR for the case that varying number of antennas, the number of user $K=3$, spreading factor $N_c=32$; number of fingers $M=3$, number of interfering cells $M_c=7$, number of Multipath $L=8$, code rate $r=2/3$, and constraint length $C_L = 3$. The result shows that for as SNR=8 dB, it is found that BER= $2.8 * 10^{-3}$ at single antenna; BER = $2.15 * 10^{-4}$ at $N_a=4$; while BER decrease to $=7.9 * 10^{-6}$ at antenna array ($N_a=9$); BER decrease so for increase number of antenna, there is a tremendous improve- ment in the BER depending on the increase number of antenna. At the same other factor. We also see that a high advantage in the system performance was obtained by using antenna array.

In Fig.12: shows the BER vs SNR for the case that varying number of channel multi paths; the number of user $K=3$, spreading factor $N_c=32$, the number of antenna=4, number of fingers $M=3$, number of interfering cells $M_c=7$, number of Multipath $L=8$, code rate $r = 2/3$, and constraint length $C_L = 3$. The result shows that for as SNR=8 dB, it is found that BER= 0.7 at using CDMA system only; BER = $2.78 * 10^{-3}$ at using SDMA- CDMA system; BER = $8.7 * 10^{-6}$ at using SDMA- CDMA and Rake receiver while BER decrease to $=1.7 * 10^{-6}$ at using SDMA- CDMA, Rake receiver and coding. We see that BER performance will considerably improve if we use SDMA Techniques, Rake Receiver, and Viterbi decoder.

In Fig.13: shows the BER vs SNR for the case that varying number of users K ; spreading factor $N_c=32$, the number of antenna=4, number of fingers $M=3$, number of interfering cells $M_c=7$, number of Multipath $L=8$, code rate $r=2/3$, and constraint length $C_L = 3$. The result shows that for as SNR=8 dB, it is found that BER= $2.4 * 10^{-5}$ at using 2 user; BER= $3 * 10^{-4}$ at using 4 user; BER= $2.8 * 10^{-3}$ at using 8 user; BER= $5.2 * 10^{-3}$ at using 10 user; BER=0.014 at using 15 user while increase BER=0.025 at using 20 users. We see that BER performance will considerably increase if we use increase number of users.

In Fig.14: shows the BER vs SNR for the case that varying number of Multi paths without coding, the number of user $K=3$, spreading factor $N_c=32$, the number of antenna=4, number of fingers $M=3$, number of interfering cells $M_c=7$. The result shows that for as SNR=8 dB, it is found that BER= $3.6 * 10^{-4}$ at using 2 multipath; BER= $1.5 * 10^{-3}$ at using 5 multipath while BER= $5.3 * 10^{-3}$ at using 10 multipath. We see that BER performance will value of there is only 1 dB degradation between the case $L=2$ and the case $L=10$. This limitation in performance degradation is due to the resistance of Rake receiver against multipath phenomena.

In Fig.15: shows the BER vs SNR for the case that varying number of Multi paths with and without coding, the number of user $K=3$, spreading factor $N_c=32$, the number of antenna=4, number of fingers $M=3$, number of interfering cells

$M_c=7$, code rate $r=2/3$, constraint length $C_L = 3$. The result shows that for as $SNR=8$ dB, it is found that $BER= 1.09 \times 10^{-4}$ at using 2 multipath; $BER= 8.6 \times 10^{-4}$ at using 5 multipath while $BER= 4.03 \times 10^{-6}$ at using 10 multipath; We see that BER performance will BER value of there is only 3 dB degradation between the case $L=2$ and the case $L=10$. This limitation in performance degradation is due to the resistance of Rake receiver against multipath phenomena.

In Fig.16: shows the BER vs SNR for the case that varying number of fingers; the number of user $K=3$, spreading factor $N_c=32$, the number of antenna=4, number of fingers $M=3$, number of interfering cells $M_c=7$, code rate $r=2/3$, constraint length $C_L = 3$. The result shows that for as $SNR=8$ dB, it is found that $BER= 0.012$ at using 2 fingers; $BER= 5.09 \times 10^{-4}$ at using 4 fingers while $BER= 2.5 \times 10^{-5}$ at using 6 fingers; We see that BER performance will increase the number of fingers from 2 to 3,4 there is about 2dB, 4dB advantage in BER performance. Thus we will get the advantage in BE performance if we increase the number of fingers in Rake Receiver.

In Fig.17: shows the BER vs SNR for the case that varying number of interfering cells M_c , spreading factor $N_c=32$, number of antenna=4, the number of users $K=3$, number of fingers $M=3$, number of Multipath $L=8$, code rate $r=2/3$, and constraint length $C_L = 3$. The result shows that for as $SNR=8$ dB, it is found that $BER= 2.9 \times 10^{-5}$ at using 2 interfering cells; $BER= 1.3 \times 10^{-4}$ at using 4 interfering cells, $BER= 4.8 \times 10^{-4}$ at using 8 interfering cells ; $BER= 1.2 \times 10^{-3}$ at using 12 interfering cells, while $BER= 3.7 \times 10^{-3}$ at using 20 interfering cells. Thus we see that BER performance will degrade if we increase the number of interfering cells.

In Fig.18: shows the BER vs SNR for the case that varying number of spreading factor N_c ; the number of user $K=3$, number of antenna=4, number of fingers $M=3$, number of interfering cells $M_c=7$, number of Multipath $L=8$, code rate $r=2/3$, and constraint length $C_L = 3$. The result shows that for as $SNR=8$ dB, it is found that $BER= 7.8 \times 10^{-3}$ at using 8 spreading factor; $BER= 1.1 \times 10^{-4}$ at using 32 spreading factor, $BER= 9 \times 10^{-8}$ at using 256 spreading factor, while $BER= 1.8 \times 10^{-8}$ at using 512 spreading factor

Thus we will get the advantage in BE performance if we increase the spreading factor from 8 to 32, 256 and 512 there is about 4.7 dB, 6 dB, 10 dB, 12dB advantages in BER performance of Rake Receiver.

5 – CONCLUSION:

The radiation patterns of the uniform Linear array (ULA) antenna (Broadside array and Endfire array) was evaluated for different antenna parameters for purposes of obtaining a directive multi spot beams to be used in the base station of SDMA-CDMA mobile system for the reverse link (up link) transmission to improve system capacity. Different antenna directivities (number of antenna array) was considered (2,4, and 9) and a suitable design parameters was chosen so as to obtain a ULA antenna with suitable mechanical dimensions ($d\lambda$) to be mounted on the base station. The BER of SDMA and CDMA was compared considering frequency Selective multipath Rayleigh Fading Channel and adjacent cells interference.

Code Division multiple Accesses (CDMA) becomes one of potential candidates for the physical layer of 4G mobile systems with the aim of improving cell capacity communication in addition to its efficient application in the 3rd generation. In this paper, the bit error rate (BER) performance of an a synchronous (reverse link) SDMA-CDMA system over a frequency selective multipath Rayleigh fading channel was performed, considering $2/3$ rate convolution encoder at the transmitter and Rake Receiver plus Viterbi decoder at the Receiver. From the numerical results we have also seen that BER performance will increase, if we increase the (number of antenna) directivity of base station antenna (at BER = there is 4 dB advantage with increasing the value of Number of antenna from 4 to 9).

The BER performance also degrade, if we increase the number of users (at BER = there is about 10 dB degradation with the increase of the users from 2 to 20). we have seen that the BER performance of Rake Receiver without coding has a limited degradation, if we increase the number of multipath (at BER = there is only 3 dB degradation with increasing the number of multipath from 2 to 10) , and this result reflects the fact that the Rake Receiver had a high resistivity against multipath effect. we have seen that the BER performance of Rake Receiver with and without coding has a limited degradation, if we increase the number of multipath (at BER = there is only 3 dB degradation with increasing the number of multipath from 2 to 10) , and this result reflects the fact that the Rake Receiver had a high resistivity against multipath effect. We have also seen that the BER performance will also increase, if we increase the number of fingers in Rake Receiver (at BER = there is about 4dB advantage by increasing the number of fingers from 2 to 4). We have also seen that the BER performance degrade, if the number of interfering cells increase (at BER = there is about 5 dB degradation with interfering cells increase from 1 to 19), but BER performance will increase, if we increase the spreading factor (at BER = there is about 9 dB advantage with increasing the spreading factor from 8 to 64).

The Space Division Multiple Access (SDMA) technique is compatible with almost any modulation method, bandwidth, or frequency band ,it can be integrated with conventional access techniques, such as FDMA, TDMA and CDMA; and can be implemented with a broad range of array geometries and antenna types such as smart antenna, therefore it can be used in all the mobile systems. It allows smart antennas offer several advantages over omnidirectional antennas; these include increased coverage through range extension and increased capacity. The dual purpose of a smart antenna system is to augment the signal quality of the radio-based system through more focused transmission of communications systems.

6- REFERENCES

- [1] T.S. Rappaport, "Wireless Communications Principles and Practice", Prentice Hall, New Jersey,1996.
- [2] "Wideband DS-CDMA for Next-Generation Mobile Communications Systems", IEEE Communication Magazine September,1998

- [3] Md. M. Hossain, Md. M.Rahman, and Md. A. Alim. "Performance Analysis of Uplink & Downlink Transmission in CDMA System", JOURNAL OF TELECOMMUNICATIONS, VOLUME 1, ISSUE 1,84, FEBRUARY 2010.
- [4] F.B. Gross, "Smart Antennas for Wireless Communications with Matlab", McGraw-Hill; 2005 .
- [5] G. L. Stuber, "Principles of Mobile Communication". Boston, MA: Kluwer, 1996.
- [6] MD.M.Hossain, J. Hossain. "Error Performance Analysis to increase Capacity of A Cellular System Using SDMA" . Journal of Telecommunications, Volume 1, Issue 1, February 2010.
- [7] J. S Proakis, " Digital Communications", McGraw-Hill, New- York, 2001.
- [8] Pravindra Kumar et al., "BER Performance Analysis of Rake receiver in Rayleigh Fading Channel for UMTS environment", International Journal of Engineering Science and Technology, Vol. 2(6), pp.1690-1698. June 2010.
- [9] Rim Haddad , Ridha Bouallegue,"A simple Method to calculate The Error Probability of Multiuser Multi-Antenna Receiver over Frequency Rayleigh Channel". International Journal of Wireless (IJWMN), Vol.2, No.1, February 2010.
- [10] John L. volaks, "Antenna Engraining" Hand book, McGraw-Hill, 2007, USA.
- [11] Balanis, C.A., "Antenna Theory: Analysis and Design," John Wiley & Sons, New York, N.Y., 2005
- [12] Krauss.J D. "Radio astronomy antennas", Tata McGraw hill, 1996
- [13] Amanpreet kaur, Amandeep Singh, "Comparison between the radiation patterns of uniform circular array and uniform planar array." International Journal of Computer Networks and Wireless Communications (IJCNWC), ISSN: 2250-3501, Vol.2, No.2, April 2012
- [14] Amanpreet kaur, zonunmawii, Shakti raj chopra, "Comparison between the radiation pattern of broadside array and end fire array". National conference on challenges in emerging computer technologies (CECT'2012), vol.4, pp 135-137.
- [15] Joseph C. Liberti, and Theodore S. Rappaport, "Analytical Results for Capacity Improvements in CDMA", IEEE Trans on Veh. Technol ., Vol. 43, NO, 3, August 1994.
- [16] J. S Proakis, "Digital Communications", McGraw-Hill, New-York, 1995.
- [17] Pravindra Kumar, "Analytical Results to Improve the Capacity of A Cellular System In Frequency Selective Rayleigh Fading Channel", International Journal of Engineering and Technology Vol.2 (5), 2010, PP-354-358.
- [18] U. Spagnolini, "A simplified model for probability in error in DS-CDMA systems with adaptive antenna arrays" IEEE Trans Actions On Wireless Communications, Vol.3, No. 2, March 2004, PP 578-587.
- [19] D. H. Johnson and D. E. Dudgeon, "Array Signal Processing: Concepts and Techniques", Englewood Cliffs, NJ: Prentice-Hall, 1993.
- [20] Tommi Heikkila, Rake Receiver, Postgraduate Course in Radio Communications Autumn 2004.
- [21] Pravindra Kumar, B.K.Kanaujia, and M. Gangadharappa, BER Analysis to Increase Capacity of A Cellular System Using SDMA Over a Multipath Rayleigh Fading Channel, (IJCSE) International Journal on Computer Science and Engineering Vol. 02, No. 04, 2010, 1196-1200.
- [22] R. bansal, R. Khanna, "BER Performance of Optimum Combining with BPSK Modulation scheme in different fading environments", accepted in National Conference on "Wireless Networks and embedded Systems organized by Electronics and Communications Department at Chitkara Institute of engineering and Technology", Rajpura to be held on 28th July 2006.

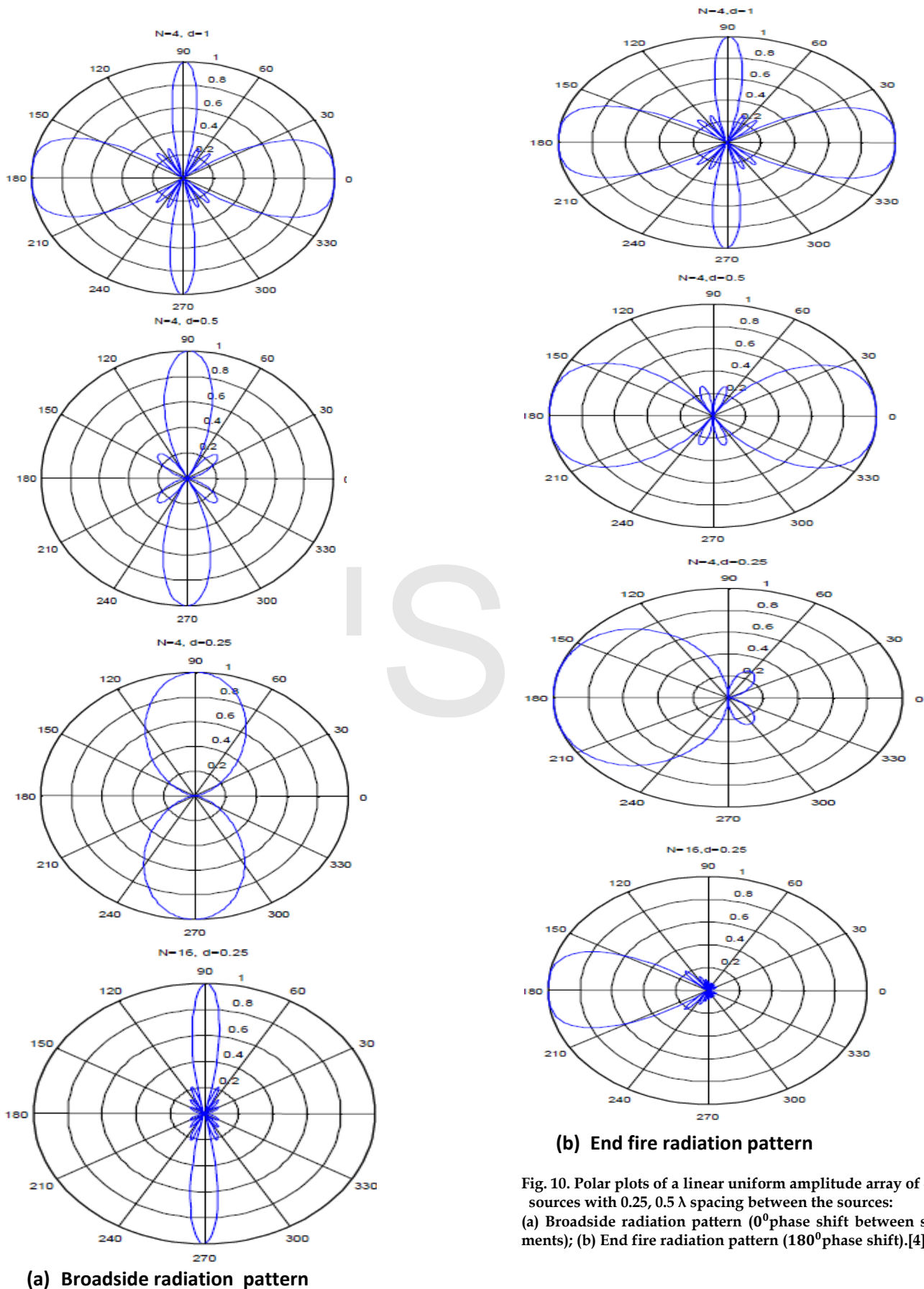

(b) End fire radiation pattern

Fig. 10. Polar plots of a linear uniform amplitude array of 4,16 isotropic sources with 0.25, 0.5 λ spacing between the sources: (a) Broadside radiation pattern (0° phase shift between successive elements); (b) End fire radiation pattern (180° phase shift).[4]

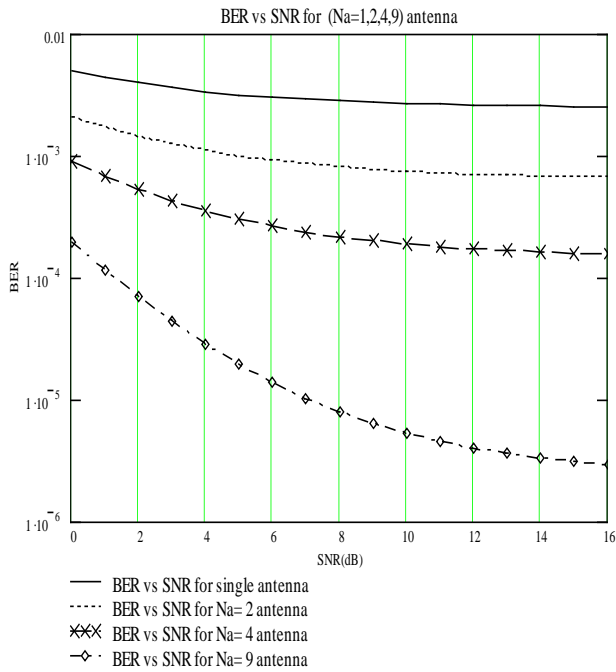

Fig.11 . BER Performance of Rake Receive with Varying the Directivity (number of antenna) of Base Station Antenna

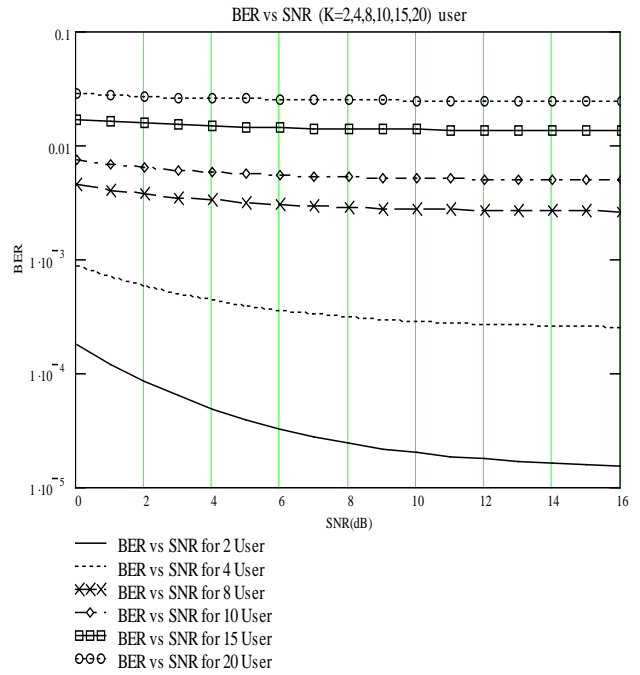

Fig.13 . BER Performance of Rake Receiver with Varying Number of Users.

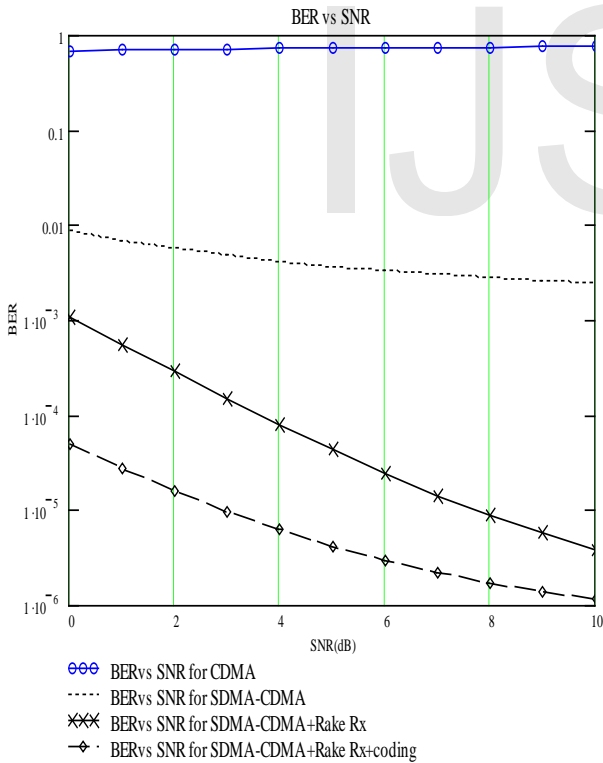

Fig. 12. BER Performance with and without SDMA and Rake Receiver.

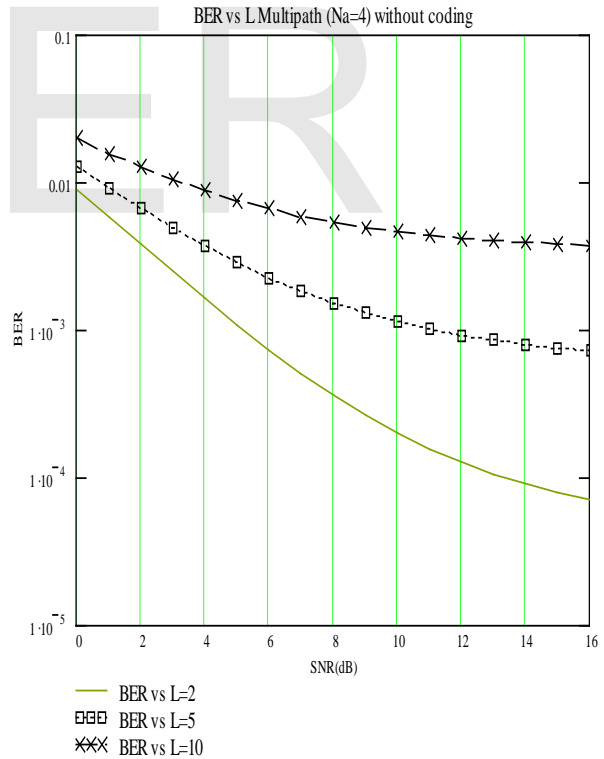

Fig.14. BER Performance of Rake Receiver with Varying Number of Multipath

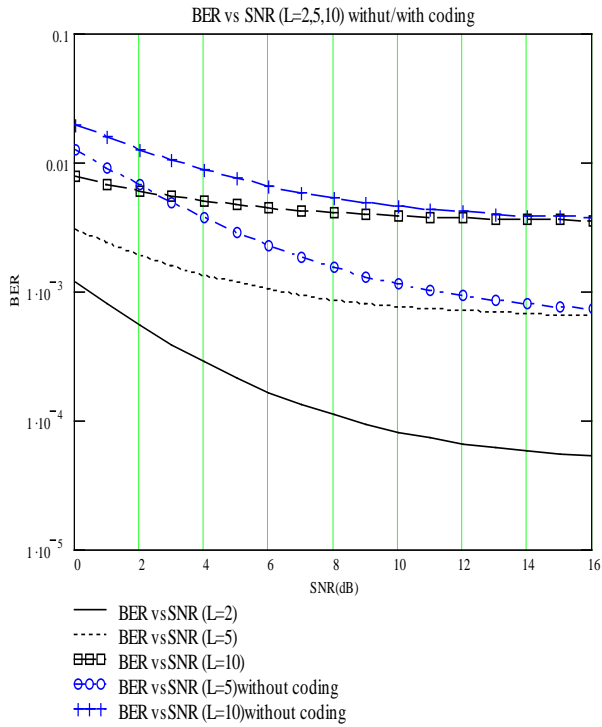

Fig.15. BER Performance of Rake Receiver with Varying Number of Multipath.

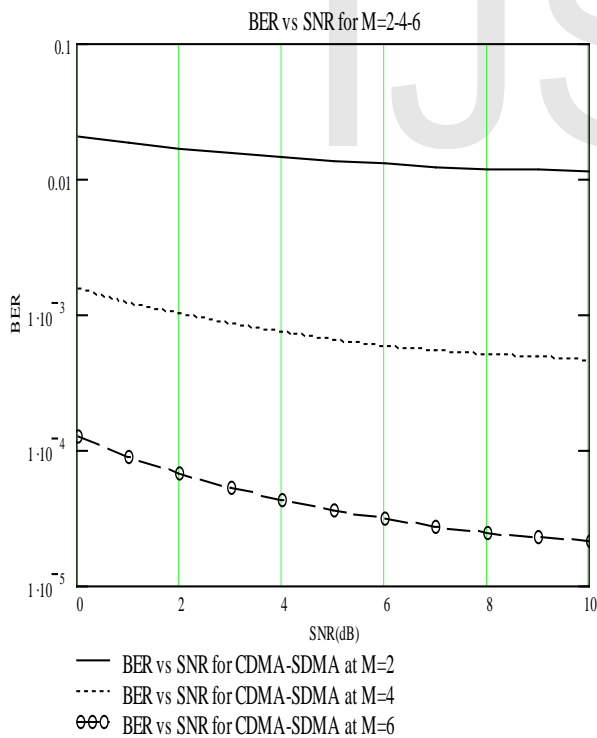

Fig.16. BER Performance of Rake Receiver with Varying Number of Fingers.

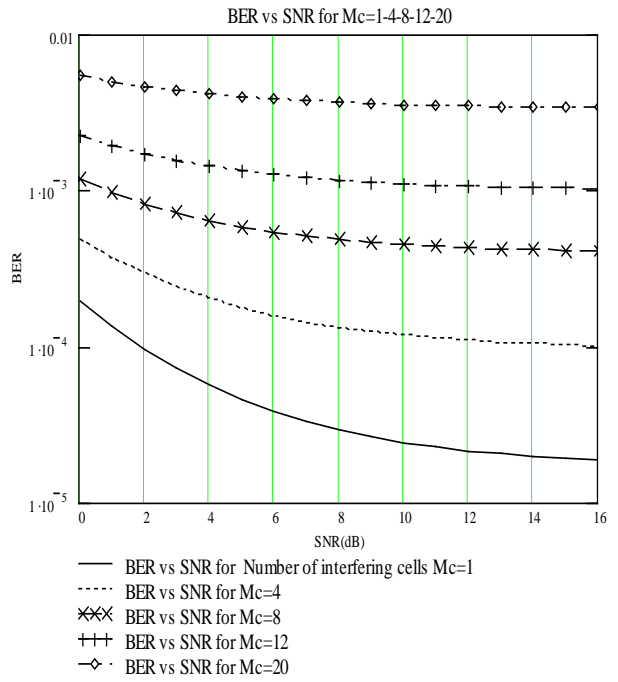

Fig.17. BER Performance of Rake Receiver with Varying Number of Interfering Cells.

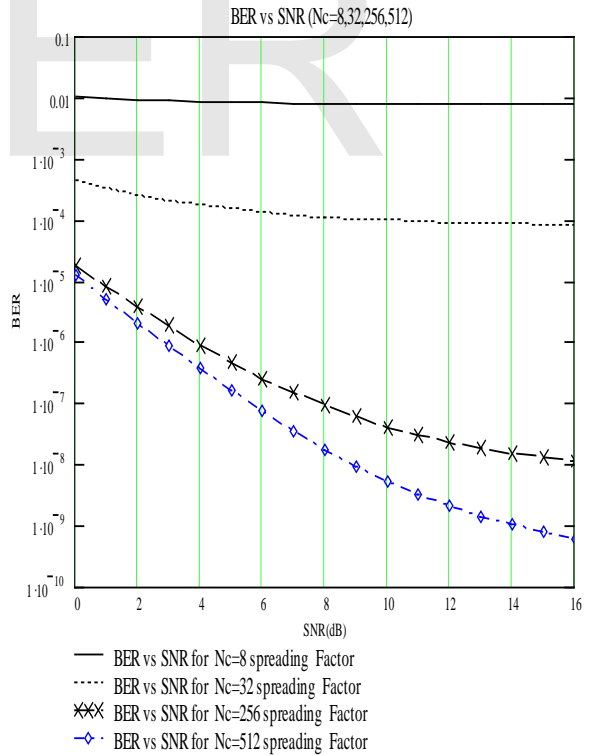

Fig.18. BER Performance of Rake Receiver with Varying Number of Spreading Factor.